

1
2
3
4
5
6
7
8
9
10
11
12
13
14
15
16
17
18
19
20
21
22
23
24
25
26
27
28
29
30
31
32
33
34
35
36
37
38
39
40
41
42
43
44

For Information Only Do not Read at Dinner

It is hard to conceive of any rituals more beautiful and inspiring or any ceremonies in Masonry more soul stirring and profound than the Tenebraê and the Feast of the Paschal Lamb or, as it is often called, the Mystic Banquet or Feast Obligatory. To our Jewish Brethren, it signifies the Feast of the Passover, which is an annual reminder of the priceless heritage of freedom and a call to struggle for it by eternal vigilance. To our Christian Brethren, it signifies the Last Supper Jesus and His Disciples attended to celebrate this ancient festival, after which there followed His death and resurrection.

The Passover was a festival instituted to commemorate Jehovah's "passing over" the Israelite houses while "passing through" those of the Egyptians in order to destroy the firstborn of each household. In the early history of these celebrations, a lamb without blemish was taken from the flock on the 10th and killed on the 14th day of the Hebrew month Abib (ear of corn) which is in the modern Hebrew Calendar the month of Nisan, which occurred at the spring of the year. The blood of the lamb was to be sprinkled on the two side posts and the upper door post, and the flesh eaten with unleavened bread and bitter herbs before the morning. Jehovah, passing over the blood-stained doors, slew the firstborn in the Egyptian houses not similarly protected. St. Paul likens the Paschal Feast to the resurrection of Christ, but, no matter what the interpretation, in Masonry it has no creedal significance. To our Brethren of the Rose Croix, it is known as the Mystic Banquet, and it is obligatory, at least in spirit, for every Knight Rose Croix, on this special day, to break bread with a Brother and partake of a portion of roasted lamb. This beautiful ceremony is but another method of bringing to our minds those great moral truths which we already have been taught. It is in that spirit that we assemble, as Masons and Brethren, bound with solemn ties and no thought of any particular creed or religion.

Where the members are gathered for dinner prior to Tenebraê, the ceremony of Extinguishing the Lights, the symbolism of the Mystic Banquet should be explained to the Knights attending the ceremonies. They are as follows:

1 1. *The Matzo*, or unleavened bread is also called Bread of
2 Affliction. It is symbolic of the bread, which the Hebrews
3 made when they hastily left Egypt, because they did not
4 have enough time to allow their dough to leaven. The Matzo
5 is the most important symbol of the Passover.

6
7 2. *The Moror* [mohr-or] or bitter herb (represented with a
8 small slice of horseradish) is symbolic of the hardships,
9 which the Israelites endured when they were slaves in
10 Egypt.

11
12 3. *The Haroses* [hahr-oh-seth] is a kind of paste of
13 apples, almonds, raisins, and wine symbolic of the mortar
14 the Israelites used when they were slaves in the
15 construction for the Pharaoh of the treasure cities Pithom
16 and Ramses.

17
18 4. *The Shank Bone* is symbolic of the Paschal Lamb that was
19 sacrificed and eaten on the eve of the Passover.

20
21 5. *The Hard-boiled Egg* is symbolic of life and springtime
22 when nature renews life.

23
24 6. *The Cup of Wine* (purple grape juice) is commemorative
25 of the promise made by God to Moses to redeem the
26 Israelites by bringing them out of bondage.

27
28 An explanation of these symbols of the Mystic Banquet gives
29 the ceremony much of its true meaning; however, the
30 preceding explanation is not ritualistic and, hence, need
31 not be included as such in any ceremony. It is not
32 permissible to substitute an actual banquet for the Mystic
33 Banquet although a dinner preceding the ceremony is
34 appropriate. See the report of the Committee on Rituals
35 and Ceremonial Forms, Transactions 1947, page 294, which
36 reads in part as follows:

37
38 It is difficult for us to make a rule that should be
39 followed in all the Bodies, because in some Valleys,
40 members travel a long distance to attend the Services, and
41 a dinner preceding the [ceremony] is found desirable. We
42 think they should not, at this time, be forbidden. In the
43 larger Valleys no problem arises because of the old custom

1 | of having a repast prior to the Service. But, we find that
2 | they do not distract seriously from the spirit and
3 | intention of the [occasion].

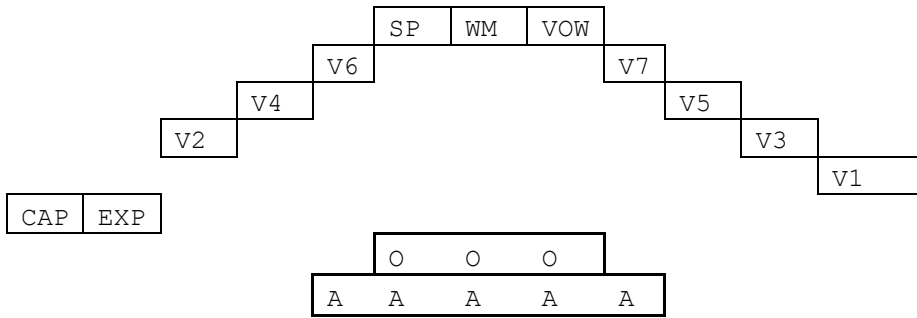

LINE UP FRONT

WM	
VOW	
SP	
V5	
CAP	
TRE	
EXP	
SEC	
V2	
V1	
V6	
V7	
V4	
V3	
MC	
OR	
AEP	
CG	
SW	
JW	

Articles Used in the Observance

- 1
- 2
- 3 1. Seven candles (a Menorah may be used, but is not
- 4 necessary)
- 5 2. Matches (do not use a cigarette lighter)
- 6 3. A bowl of water (for dousing the matches)
- 7 4. Wine and Purple Grape Juice
- 8 5. Individual cups
- 9 6. One plate of whole matzo [mat-zah] or unleavened bread
- 10 7. One dish of moror [mohr-or] or bitter herb (sliced
- 11 horseradish)
- 12 8. One dish of haroseth [hahr-oh-seth] (a paste of apple,
- 13 almonds, raisins, and wine)
- 14 9. One roasted lamb shank, with bone (the meat chopped
- 15 into bite-size morsels)
- 16 10. One hard-boiled egg in shell
- 17 11. One plate or bowl of salt
- 18 12. One unused goblet in the center of the table
- 19 13. Mystic Scroll (with names of members who died in the
- 20 past year)
- 21

22 The table, with white cover upon which these items are to
23 be arranged, may be of any shape or design. Care should be
24 taken to make sure that the candles are set firmly in their
25 holders, and a fire extinguisher should always be kept
26 nearby. The most prominent features on the table should be
27 the lights and the unused goblet. The candles are lit by
28 the Master of Ceremonies following the Mystic Banquet (or
29 the optional ten-minute address). The meat of the roasted
30 lamb should be cut into small pieces, each secured to a
31 toothpick, with the bone left in the center of the plate.

32
33 **[Optional Distribution Ceremony: Consideration should be**
34 **given to audience participation. If, however, there are**
35 **more than thirty people in the gathering, it may be wise to**
36 **limit distribution of the Mystic Banquet to the actual**
37 **Officers participating in the ceremony. The participation**
38 **of large audiences complicates and lengthens the ceremony.**
39 **This same consideration should be implemented in the**
40 **distribution of matzo, lamb, and purple grape juice.]**

Ceremony of Remembrance and Renewal, Rev 02/11/10
Setup Large Lodge Room

1. Resplendent Glory
2. Gavel, Striker Plate and Pad
3. U. S. Flag
4. Lux Tenebrae, Chair, Black Cloth
5. Runner
6. Altar
7. Black Cloth with Red Cross
8. Bible
9. Menorah (Lights Off) Mike 5
10. Table for Roses covered with white Cloth
11. Mikes
12. Chasubles
13. Gong
14. Spotlight
15. Table covered with white cloth with Mystic Scroll and Goblet
16. Mystic Scroll (Placed on the Symbolic Table downstairs)
17. 2-EA Empty Goblets (Placed on tables downstairs)

Microphones

- | | |
|------------------------------------|---|
| 1. Wise Master | - |
| 2. Senior Warden | - |
| 3. Junior Warden | - |
| 4. Guest Speaker When Appropriate | - |
| 5. Menorah | - |
| 6. Memorial Team - M Wise Master | - |
| 7. Memorial Team - M Senior Warden | - |
| 8. Memorial Team - M Junior Warden | - |
| 9. Memorial Team - M Chaplain | - |
| 10. Captain of the Guard | - |
| E. VOW | - |
| S. Orator | - |
| X. Secretary | - |

Music - Disk 1 - Ceremony of Remembrance

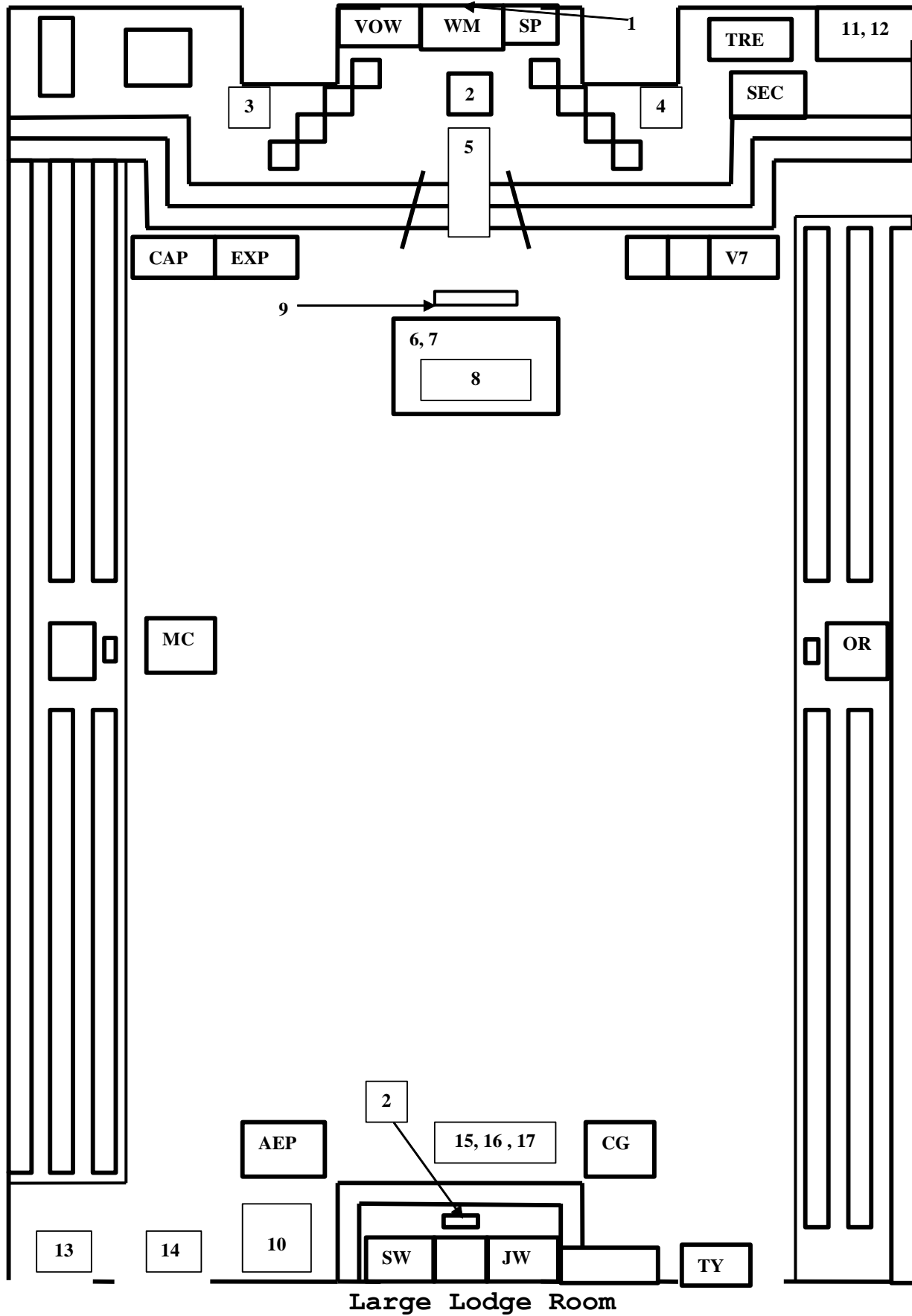

Setup Small Lodge Room

1. Gavel
2. Jewels
3. Altar with Bible, Covered with White Cloth with Gold Trim
4. Table cover with white cloth
5. Incense Burner
6. Pen
7. Paper
8. Matches
9. Bread Service
10. Wine Service

SMALL LODGE ROOM

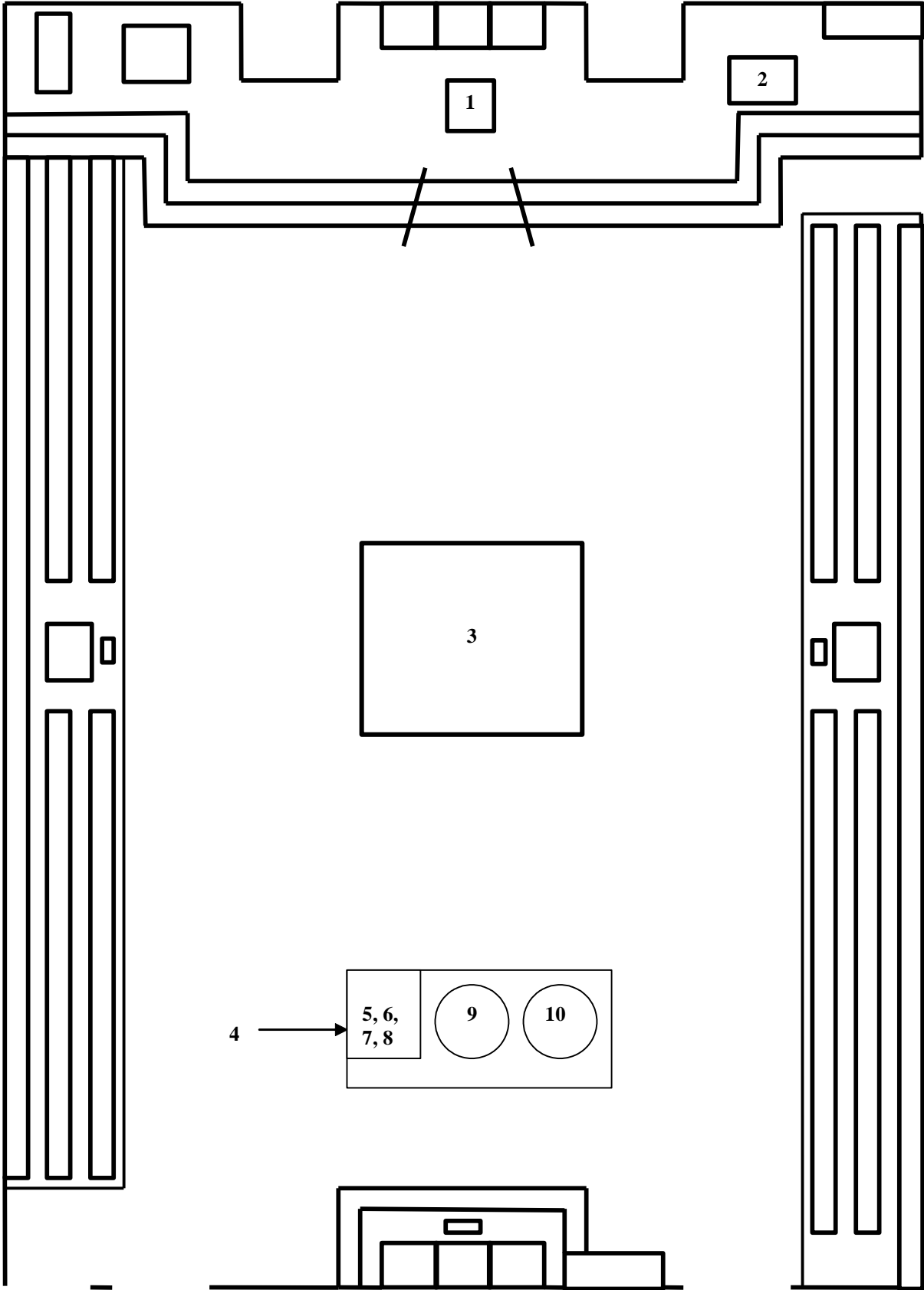

Setup for Dinner

1. Menorah
2. Matches (To light Menorah [Do not use a cigarette lighter])
3. A bowl of Water (for dousing the matches)
4. Purple Grape Juice
5. Individual Cups
6. One plate of whole *Matzo*
7. One dish of *Moror*
8. One dish of *Haroseth*
9. One roasted lamb shank, with bone (cut in small pieces, each secured to a toothpick with bone left in the center of the Plate)
10. One hard-boiled egg in shell
11. One plate or bowl of salt
12. One unused empty goblet in the center of the table
13. Mystic Scroll (with names of members who died in the past year)
14. White cover
15. Wine for the Toast

Note: If there are more than thirty people in the gathering the distribution of the Mystic Banquet can be limited to the actual Officers participating in the ceremony.

Table Setup Downstairs

Entrance

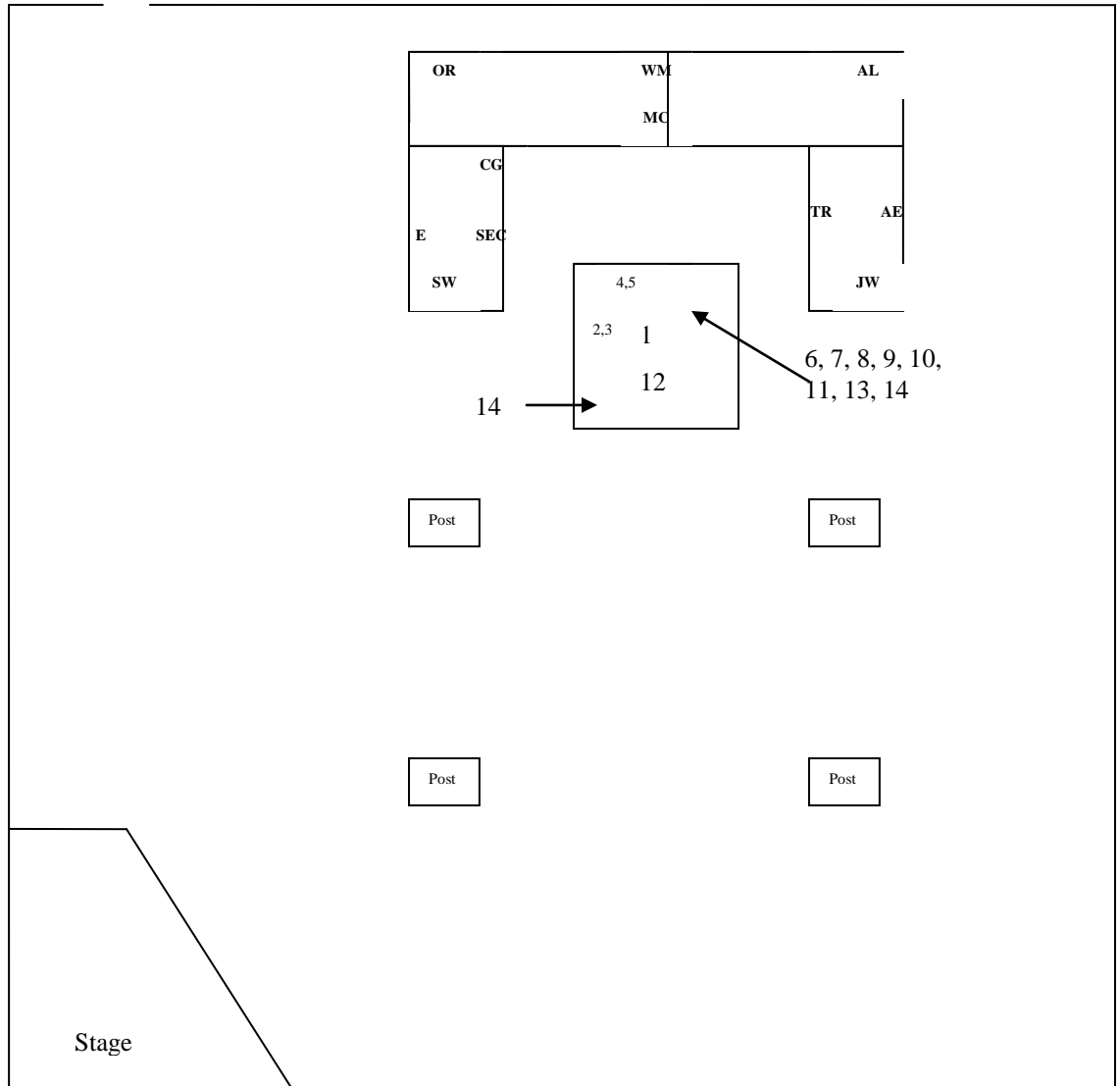

Kitchen

1 **Ceremony of Remembrance and Renewal**

2 **Part One:**

3

4 **Close and Open to be done in the Small Lodge Room**

5

6 **Wise Master:** Brothers Senior and Junior Warden,
7 request the Knights who grace your respective
8 Valleys to assist me in renewing the labor of the
9 Chapter

10

11 **Senior Warden:** Knights who grace my Valley, the
12 Wise Master request you to assist him in renewing
13 the labor of the Chapter

14

15 **Junior Warden:** Knights who grace my Valley, the
16 Wise Master request you to assist him in renewing
17 the labor of the Chapter

18

19 **Junior Warden:** Brother senior Warden, the orders
20 of the Wise Master are make known to my Valley

21

22 **Senior Warden:** Wise Master, your orders are made
23 known in both Valleys

24

25 **Wise Master:** Brother Senior Warden, what is the
26 first care when labor is to be resumed in your
27 Chapter?

28

29 **Senior Warden:** To know that the chapter is
30 perfectly tiled.

31

32 **Wise Master:** Be pleased to assure yourself that
33 it is so, my Brother, by the usual means.

34

35 **Senior Warden:** Brother Guardian of the Temple, be
36 pleased to ascertain whether the Chapter is
37 perfectly tiled.

38

39 **Guardian of the Temple:** Brother Senior Warden,
40 the Chapter is perfectly tiled.

41

42 **Senior Warden:** Wise Master, the Chapter is
43 perfectly tiled.

1

2 **Wise Master:** What is your second duty, my
3 Brother?

4

5 **Senior Warden:** To know that all present are
6 Knights Rose Croix.

7

8 **Wise Master:** Brother Senior Warden, please assure
9 yourself that all are such.

10

11 **Senior Warden:** Wise Master, all present are
12 Knights Rose Croix.

13

14 **Wise Master:** As such, on your assurance, I
15 welcome all. The peace of God, that passeth
16 understanding, be and remain with all.

17

18 **Wise Master:** Brothers Senior and Junior Warden,
19 be pleased to inform the Knights in your
20 respective Valleys that it is my intention to
21 close the chapter.

22

23 **Senior Warden:** Knights in my Valley, the Wise
24 Master informs you that it is now his intention to
25 close the Chapter.

26

27 **Junior Warden:** Knights in my Valley, the Wise
28 Master informs you that it is now his intention to
29 close the Chapter.

30

3 Raps

31 **Wise Master:** To Order Knights! *** (**Three Raps**)

32

33 **Wise Master:** To the Glory of the Great Source and
34 Author of all that is, and in the name and under
35 the auspices of the Supreme Council of the Thirty-
36 third Degree, Mother Council of the World, of the
37 Inspectors General for the Southern Jurisdiction
38 of the United States of America, and by virtue of
39 the powers vested in me as Wise Master of the
40 Bremerton Chapter of Rose Croix, I declare this
41 Chapter to be Closed.

42

43 **Wise Master:** The Chapter is called off, but
44 before we part, let us eat together the bread and

1 drink the wine to which the performance of our
2 duty entitles us, being ever grateful to our
3 Father for supplying us with the food needful to
4 our existence.

5

6 **Wise Master:** Brother Master of Ceremonies, be
7 pleased to visit the precincts of our Council
8 Chamber and ascertain whether there be any
9 Brother, or even any Profane, suffering with
10 hunger or thirst. If there be any, bring him in
11 and he shall be welcome, for whosoever he may be,
12 he is our Brother, and we shall be happy to share
13 with him our frugal repast.

Master of
Ceremonies
goes
outside
and
returns

14

15 **Master of Ceremonies:** (Goes out and returns,
16 going to Altar first and either introduces the
17 hungry or thirsty Brother or Profane or, if there
18 be none, says) There is none.

19

20

1 Rap

21 (Seat the Lodge.) *

22

23 **Wise Master:** In the circle to be formed,
24 participation is especially requested by all 33°,
25 all Knights Commander of the Court of Honor, and
26 Past Wise Masters, who will form to my right in
27 the order named. All Officers are also requested
28 to join the circle. Those not wishing to
29 participate may remain seated. Let us, my
30 Brethren, meet upon the level.

31

Form
Circle

32 [Wise Master and Personal Representative travel to
33 West and Senior and Junior Warden travel East to a
34 position West of the Alter all under the sign of
35 the Good Shepard, Brothers to participate join in
36 circle between them.]

37

38 **Wise Master:** (Prayer) Let us Prey! Sovereign
39 Creator of all things and source of light, who
40 providest for all our necessities, bless the
41 nourishment for the body, of which we are about to
42 partake, and make it give us strength to labor for
43 Thy Glory and the advancement of the great
44 interest of humanity. AMEN

1

2 **ALL:** So Mote it be.

3

Take the
Bread

4 After the Prayer, the Wise Master takes the plate
5 of bread, eats, then, after tapping the Knight
6 first on his right on the shoulder and bowing to
7 him, says:

8

9 **Wise Master:** Take, eat and give to the hungry.

10

Take the
Wine

11 (Each Knight, in succession, does the same until
12 the bread has been presented to every Knight in
13 the Circle.)

14

15 **Wise Master:** Take, drink and give to the thirsty.

16

17 (Each Knight, in succession, does the same until
18 the wine has been presented to every Knight in the
19 Circle.)

20

21 **Wise Master:** To order Knights. To the right
22 face.

23

24 [Wise Master taps Personal Representative on
25 shoulder, Personal Representative turns to face
26 Wise Master. Wise Master gives the Second Sign is
27 called the Sign of Recognition. It is to raise
28 the right hand, the forefinger pointing upward.
29 The Personal Representative gives the answer by
30 pointing to the ground with his right forefinger.
31 The Personal Representative then gives the first
32 sign and the Wise Master answers. Then each
33 places their right hand on the other's right
34 shoulder with the left hand on the other's left
35 shoulder. In this position pronounce, by
36 syllables alternating with each other, the
37 password.]

38

39 Password: -*Immanuel* [*E-man-u-el*]. The token
40 means: "God with us."

41

42 The Answer given is, *Pax Vobiscum* [*Pax*
43 *Wohbiskoom*], meaning "Peace be with you."

44

1 Rap

1 I-N-R-I INRI.

2

3 After the secret work is completed, Wise Master
4 writes down the secret word then burns the paper
5 and says: -"Consomatum EST" and **then goes to the**
6 **East and seats the Brethren. (1 Rap *)**

7

8 **Wise Master:** Peace be with you, my Brethren, and
9 remain with you always. Remember that it is
10 better to love than to hate; that your duty is not
11 to be better than your Brother, but to be better
12 than yourselves; and that the more you have, the
13 more you owe to those who need assistance. The
14 Peace of our Master be with you always.

15

16 **Wise Master:** My Brethren, As is our tradition
17 this Chapter is closed on Maundy Thursday and will
18 remain closed symbolically for three days.

19

20 Opening Chapter of Rose Croix

21

22 **Wise Master:** Knights, it is my intention that
23 this chapter of Rose Croix shall presently open
24 for the disposal of such business as may lawfully
25 come before it.

26

27 **Wise Master:** Brothers Senior and Junior Warden,
28 request the Knights who grace your respective
29 Valleys to assist me in opening this Chapter of
30 Rose Croix.

31

32 **Senior Warden:** Knights who grace my Valley, the
33 Wise Master requests you assist him in opening
34 this Chapter of Rose Croix.

35

36 **Junior Warden:** Knights who grace my Valley, the
37 Wise Master requests you assist him in opening
38 this Chapter of Rose Croix.

39

40 **Junior Warden:** Brother Senior Warden, the orders
41 of the Wise Master are made known to my Valley.

42

43 **Senior Warden:** Wise Master, your orders are made
44 known in both Valleys.

1

2 **Wise Master:** Knights, let us acknowledge our
3 duties and renew our obligations to God and the
4 Order. Give your attention to ILL. James Neil
5 Reid Jr. who will lead us in the obligation. ***

3 Raps

6 **Three Raps**

7

8 **VOW:** Upon my pledge of honor, as a true Knight
9 and Mason, I promise and vow, that I will labor
10 without tiring, to effect the purposes, and
11 enforce the principles of Scottish Masonry, and
12 especially to convince men, of the Great Truth, of
13 which the word of a Knight Rose Croix, is the key
14 and symbol, that I will never abandon, the cause
15 of freedom of action, speech and conscience, or
16 that of the Brotherhood of the Holy House. So
17 help me God. AMEN.

18

19 **ALL:** So Mote it be.

20

21 **Wise Master:** May no Knight prove disloyal or
22 foresworn!

23

Raises
Right Arm

24 **Wise Master [Raises Right Arm]:** In the name and
25 under the auspices of the Supreme Council of the
26 Thirty-third Degree, of the Inspectors General for
27 the Southern Jurisdiction of the United States of
28 America, and by virtue of the powers vested in me
29 as Wise Master of the Bremerton Chapter of Rose
30 Croix, I declare this Chapter called from labor to
31 refreshment. (1 Rap *)

1 Rap

32

33

34

35

36

37

38

39

40

41

42

43

44

1 FINISH
2 Part Two

3
4 To be read at dinner downstairs

5
6 **Mystic Banquet** - (Takes place at dinner before the
7 regular meal).

8
9 Instructions for the mystic banquet portion of the
10 feast of remembrance. This is to be performed
11 after the prayer of thanksgiving and prior to
12 going through the buffet to get the regular meal.

13
14 Each table in the banquet hall is setup with:

- 15
16 **Plate of Matzo Bread**
17 **Plate of cubed cold roasted lamb**
18 **Bowl of Haroseth** (paste of almonds, apples,
19 raisins, and wine)
20 **Bowl of sliced horseradish**
21 **Plate of quartered hard-boiled eggs**
22 **Carafe of red wine and purple grape juice**
23 **A small dish of salt** (preferably Kosher or
24 Kitchen)

25
26 **Wise Master:** Brother Prelate will you lead us in
27 prayer.

28
29 **Prelate:** Offers a Prayer. Amen. So Mote it Be.

30
31 **Wise Master:** Now Brethren and Knights attend with
32 me the Mystic Banquet.

33
34 *Takes a piece of Matzo bread and holds it up.*
35
36
37
38
39
40
41
42
43
44

34 *Takes a piece of Matzo bread and holds it up.*
35
36 Brethren, I give to you all the Bread of
37 Fraternity. You will receive it as a group,
38 taking you lead from me. Take, eat, and give to
39 the hungry.

41 *All eat bread*

41 *All eat bread*
42
43
44

All Eat Bread

1 **Senior Warden:** The feast of the Passover was first
2 observed by the Hebrews in Egypt. On the tenth
3 day of the first month, the people were ordered to
4 take a lamb in its first year, without blemish,
5 arrange themselves by families in numbers suitable
6 for its consumption, and keep the lamb until the
7 fourteenth day of the month when it was to be
8 slain, roasted, and eaten with unleavened bread.
9 The blood of the lamb was also placed on the
10 doorposts and lintels of the houses during this
11 observance. The Destroying Angel, seeing this
12 blood, passed over the homes of the Hebrews and
13 slew the firstborn of the Egyptians. Thus the
14 blood of the Passover Lamb symbolized the
15 redemption and is here thus symbolized by the
16 shank bone.

17

18 This ceremony of Passover is observed by the
19 Jewish people to this day.

20

Points to
each item
as
mentioned

21 **Senior Warden gestures to each as he mentions them**

22

23 The moror, or bitter herbs, is symbolic of the
24 hardships, which the Israelites endured while they
25 were slaves in Egypt.

26

27 The haroseth, a paste of apples, almonds, raisins
28 and wine is symbolic of the mortar the Israelites
29 used in the construction of the Pharaohs' treasure
30 cities of Pithem and Ramses.

31

32 The salt and hard-boiled egg is symbolic of
33 hardship and renewal.

34

35 Two thousand years ago Jesus of Nazareth also
36 celebrated the Passover Feast with His Disciples.
37 His observance of this Feast is now known by
38 Christians as the Last Supper. As such, it was
39 instituted as the sacrament of Holy Communion.

40

41 **Wise Master:** Here, we partake of the lamb, which
42 has in all ages been deemed an emblem of
43 innocence, not as a religious ceremony, but in
44 remembrance of the Great Commandment of the New

1 Law of Love, which surpasses all boundaries. By
2 this act we signify our desire to reconcile with
3 anyone we have wronged so that we may be innocent
4 of malice. Let us also, thereby, renew our vows
5 to humanity at large. Knights, **(Junior and Senior**
6 **Wardens receive the Paschal Lamb)** Brethren, I give
7 you the Paschal Lamb. You will receive it as a
8 group, taking your lead from me
9

Holds up
Lamb

10 *Takes a cube of cold roasted lamb and holds it up*
11

12 Let us remember the admonition: "A new commandment
13 I give unto you, That ye love one another."
14

All Eat
Lamb

15 *All eat lamb*
16

17 **Junior Warden:** Wine is the Masonic symbol of the
18 refreshment. Let it, therefore, remind us of the
19 first fruits of the earth, and of spring's renewal
20 and bounty. The earth does not withhold her gifts
21 from any man because of color, creed, location, or
22 nationality.
23

Points to
Goblet

24 *Gestures to goblet.*
25

26 Even so, let this empty goblet, in the center of
27 the table, teach us kindness and generosity with
28 the needy, whether he is friend or stranger. In
29 moderation, wine makes the heart glad, but in
30 excess, it causes men to stumble and err. Let
31 this wine also recall our first lesson in Masonry:
32 to circumscribe our desires and keep our passions
33 within due bounds. In the spirit of renewal, hope
34 and joy for the ensuing year, let us now partake
35 of this wine.
36

37 **Wise Master:** Brethren, charge your goblets.
38

Three Raps

39 *Three Raps ****
40

Charge
Goblets

41 *All pour a goblet of wine or grape juice.*
42

43 **Wise Master:** Brethren, in the spirit of renewal,
44 hope, and joy for the ensuing year. I give to you

1 all the fruit of the vine. You will receive it as
2 a group, taking your lead from me.
3 Take, drink, and give to the thirsty.

4

All Drink
Wine

5 *All drink together*

6

7 **Wise Master:** Brethren charge you glasses and join
8 me in the Toasts of Obligation.

9

Drink
after each
Toast

10 1. To the United States of America.

11 **Response:** "To the United States of America"

12

13 2. To the Supreme Council.

14 **Response:** "To the Supreme Council"

15

16 3. To the Sovereign Grand Commander ILL Ronald A. Seale"

17 **Response:** "To the Sovereign Grand Commander:

18

19 4. To the Most Worshipful Grand Lodge, Free and Accepted
20 Masons of Washington and the Grand Master.

21 **Response:** "To the Grand Lodge and the Grand
22 Master"

23

24 5. To the Sovereign Grand Inspector General ILL William R.
25 Miller.

26 **Response:** "To the Sovereign Grand Inspector
27 General of Washington:

28

29 6. To the Grand Bodies of Washington.

30 **Response:** "To the Grand Bodies:"

31

32 7. To Visiting Brethren and Guests if any are present (**Give
33 Names and Titles**)

34 **Response:** "To our Guest"

35

36 8. To the memory of all Brethren of this Degree who have
37 passed from this realm of earthly labor during the present
38 Masonic year.

39 **Response:** "To our Deceased Brethren"

40

41

42

43

44

1 9. To all Masons and Masonic Bodies, of all Rites and
2 Degrees, across the lands and oceans of the world: acclaim
3 to be worthy; restoration to the ill; help to the needy; and
4 succor to the oppressed of all nations.

5 **Response:** "To all Masons wheresoever disbursed."
6
7

1 Rap

8 **Wise Master:** * Knights, Brethren, Friends, this
9 concludes the ceremonial portion of our mystic
10 Banquet. Please go to the buffet beginning with
11 the table on my right.

12

13 *After the meal, but before adjourning, there will*
14 *be a message by guest speaker.*

15

16

17

18 **End of program**

19

20

21

22 **Instructions for Service:**

23

24 Purchase 6 liters of red wine.

25 Purchase half gallon of Welsh's purple grape
26 juice.

27 Purchase ~ 60 plastic goblets

28 Secure enough carafes for each table for both wine
29 and juice

30 Purchase a Large pack of Matzo bread

31 Purchase a Box of Kosher Salt

32

33

34

35

36

37

38

39

40

41

42

43

44

Music (5)	1	Part Three
CD-1	2	
Track-1	3	Tenebraê, Extinguishing of the Lights
	4	
	5	Note: Scottish Rite caps should be worn during
	6	this entire observance.
	7	
	8	[Officers rise to their feet prior to speaking
	9	their parts and sit down when they are finished
	10	speaking.]
	11	
Fade Music	12	Officer parade in under the Sign of the good
1 Rap	13	Shepard. (1 Rap) *
	14	
	15	
	16	1 - Wise Master: Brethren and Knights, we
	17	assemble in the spirit of fraternity at the vernal
	18	equinox, the commencement of spring, to renew
	19	acquaintances, to remember our friends, and to
	20	pledge ourselves to aiding humanity. We are
	21	taught that before commencing any laudable
	22	undertaking, we should first invoke the aid of
	23	Deity. Brothers and Guest in attendance, you will
	24	now, therefore, rise and bow your heads with me,
	25	under the Sign of the Good Shepherd. Brother
3 Raps	26	Orator. (Three Raps) ***
	27	
	28	[After the Brethren rise, all Officers bow their
	29	heads under the Sign of the Good Shepherd.]
	30	
Next Music	31	S - ORATOR: Great Architect of the Universe,
(3)	32	source of all Light and giver of all good graces,
	33	be with us now as we remember the true purposes of
CD -1	34	our Fraternity. Grant us health, peace, and
Track-2	35	wisdom that our days may be long and fruitful.
	36	Let us remember the lessons and sacrifices of
	37	those who have gone before us so that we may, by
	38	their examples, better our own lives and those of
	39	our fellowmen. To the glory of Thine Ineffable
	40	Name, Amen.
	41	
1 Rap	42	ALL: So mote it be. (1 Rap *)
	43	
	44	[The Brethren take their seats.]

1
2 **1 - WISE MASTER:** Brother Master of Ceremonies,
3 you will light the tapers.
4
5 **[The Master of Ceremonies either lights the**
6 **candles or, if electric, turns on their switches.**
7 **He then resumes his seat.]**
8
9 **1 - WISE MASTER:** Now, Brethren and Knights,
10 attend with me the most solemn purpose of our
11 gathering, that we may recall those who, loving
12 mankind, gave all that they possessed, and were
13 rewarded with death.
14
15 **[A pre-selected Brother, who is either off-stage**
16 **or near the light switch, dims the lights in the**
17 **room.]**
18
19 **5 - Voice 1:** When the Great Architect created the
20 heavens and the earth, there was darkness, and He
21 alone was the One True Light. But He was pleased
22 to place lights in the sky that His
23 creatures might both live and see. Even so,
24 throughout history men have appeared to dispel the
25 darkness of fanaticism and superstition with the
26 Light of Truth. Whether poet, religious leader,
27 scientist, or social reformer, all who sought to
28 elevate humankind brought with them the Light of
29 Truth. But the people, often blinded by vices,
30 put them to death.
31
32 **[Voice 1 extinguishes the first of seven lights or**
33 **candles, commencing with one of the outermost on**
34 **either side. The subsequent lights should be**
35 **extinguished from the outside in, alternating each**
36 **time, leaving the center light for last.]**
37
38 **5 - Voice 2:** Their pure and lofty lessons were
39 intended to ensure the happiness of mankind by
40 proclaiming perfect equality and freedom; but the
41 people knew them not and put them to death.
42
43 **[Voice 2 extinguishes the second light, on the**
44 **opposite far end, as described above.]**

Dim Lights
as lights
are
switched
off

Music (2)

CD-1
Track -5

Lower as
each
Speaker
Speaks
Spotlight
on Menorah

1

2 **5 - Voice 3:** They came to persuade all men to be
 3 upright and to become one family of Brethren; but
 4 the people knew them not and put them to death.

5

6 **[Voice 3 extinguishes the third light.]**

7

8 **5 - Voice 4:** They endeavored to illuminate the
 9 mind with science, philosophy, and knowledge; but
 10 the people knew them not and put them to
 11 death.

12

13 **[Voice 4 extinguishes the fourth light.]**

14

15 **5 - Voice 5:** They came to teach Charity and to
 16 put loving-kindness in the place of greed, hatred,
 17 and persecution; but the people knew them not and
 18 put them to death.

19

20 **[Voice 5 extinguishes the fifth light.]**

21

22 **5 - Voice 6:** They came to lead mankind through
 23 the darkness of the night of ignorance by
 24 proclaiming that the immortal part of man is a ray
 25 of the Divine Light; but the people knew them not
 26 and put them to death.

27

28 **[Voice 6 extinguishes the sixth light.]**

29

30 **5- Voice 7:** They came to ensure that mankind was
 31 protected from brutality and that individual
 32 liberty was to be preserved; but the people knew
 33 them not and put them to death.

34

Fade Music 35 **[Voice 7 extinguishes the seventh and last light.**
 36 **The meeting room should now be very dim or, for**
 37 **dramatic effect, nearly dark except for a light on**
 38 **the Altar]**

39

40

41

42

43

44

Spotlight
On Orator

1 Remembrance of Recently Deceased Brethren

2

3 **S - ORATOR:** In all ages, mankind has brutally
4 murdered its liberators, reformers, and best
5 exemplars. To us, in this season, we need look no
6 further than the Apostle of Liberty, Equality, and
7 Fraternity who was crucified 2000 years ago for
8 proclaiming the Law of Love. No greater law has
9 been uttered than His simple words, "Love one
10 another:" At the very least, He was a great
11 teacher of mankind, and whatever our private views
12 may be beyond that, none can dispute the wisdom of
13 the New Law.

14

15 The Great Architect mercifully hides from our
16 vision what is to befall us in the future. We
17 know not what tragedies await us on the morrow.
18 For this reason, let us work while it is yet day,
19 and let us endeavor to fulfill our duties and
20 dispel the darkness, which you see here
21 represented. Let each of us bring light to the
22 world by the practice of virtue, and let us labor
23 for its own sake, knowing that he who sows does
24 not always reap. But rest satisfied, my Brethren
25 and Knights that you labor not in vain, for if one
26 life is benefited or improved by your own, you
27 have done well.

28

29 With whom do you stand my Brethren? Are
30 there faces in this group, which you will not see
31 next year? Will you lay a friend and Brother to
32 rest?

33

34 **1 - WISE MASTER:** Spring is a time of beginning,
35 but also of remembrance. As nature offers gifts
36 of renewal following the dead of winter, she
37 reminds us that she is immortal and that from
38 apparent death springs life eternal. The hard
39 black earth softens and is broken by the tender
40 green shoots that promise to renew the gift of
41 life by seed and fruit. By this renewal, nature
42 offers hope that man will survive the grave and
43 that he is, in some measure, immortal. Thus, life
44 continues.

1 With whom do you stand my Brethren? Are there
2 faces lacking from this group which you knew in
3 the past year? Have you laid a friend and Brother
4 to rest?

5

6 On this occasion, let us celebrate the lives
7 and commemorate the deaths of our Brethren who
8 have passed on so that we may ever keep them with
9 us while we live. For no man is ever truly dead
10 as long as he lives in the hearts and memories of
11 his friends and loved ones, and if his influences
12 continue to act for good.

13

14 **S - ORATOR:** Wherever they may be, the Knights
15 Rose Croix form a great circle which encompasses
16 the past as well as the present. The same vows
17 and duties that bind us to each other bind us to
18 our ancestors, for we have received our
19 inheritance through them. This fraternal chain,
20 called the Mystic Circle, is forged of links,
21 which pass into eternity. It becomes our duty,
22 therefore, to honor our Brethren past as we renew
23 our fraternal ties to our Brethren present.
24 Remember always that perfect love knows no death
25 and that what virtue unites death cannot separate.

26

27 **1 - WISE MASTER:** My Brethren, let us now recall
28 by names those of our number who, in the past
29 year, have completed their earthly labors.

MUSIC (3)
CD - 1
Track - 2 &
3

30 Brother Secretary, you-will take up the Mystic
31 Scroll and read aloud the names of our Brethren
32 and Knights who are recently deceased.

33

RING 1
GONG
AFTER EACH
NAME IS
CALLED

34 **X - Secretary:** Brethren attend, recorded here, as
35 in our hearts and memories, are the names of our
36 honored dead. We shall miss them. **(Reads Names of**
37 **deceased Brethren)**

38

39

40

41

42

43

44

Raise Lights
to 40
Percent

Scottish Rite Funeral Service

1
2
3 (There is a brief pause for the funeral team to
4 depart and return)
5
6

7 **6 - M Wise Master:** Knights and Brethren, again we
8 lament the loss of a brother who sleeps the sleep
9 that knows no waking and, submitting to the will
10 of God, adoring him as our Creator and Preserver,
11 and trusting in his mercy as our Father, let us
12 proceed to do what duty demands. The body of our
13 beloved Brother, _____, a 32° Degree
14 Scottish Rite Mason, lies before us, overtaken by
15 that fate which must sooner or later overtake us
16 all, and which no worth or virtue, no wealth or
17 honor, no tears of friends or agony of loved ones
18 can avert or delay; thus, teaching us the
19 impressive lesson, continually repeated, yet soon
20 forgotten, that every one of us must depart this
21 life, and that our soul must be what we have
22 chosen to make it, even as man makes it here, by
23 living well or ill.

24
25 **7 - M Sr. Warden:** We, following our ancient
26 Masonic custom and obeying the commands of duty,
27 do not pay these last honors to our Brother's
28 memory. Him, they cannot profit. He is beyond
29 the reach of honors and censure alike. To us,
30 they may, and should, be profitable. They gratify
31 those whom he loved; they show our appreciation of
32 his virtues; they encourage others to labor and
33 endeavor to deserve like honors; and they show to
34 the world that the ties, sympathies and
35 obligations of Masonry cannot be snapped asunder
36 by the hand of Death; for that man is esteemed to
37 die miserable for whom none, save those of his own
38 household, shed a tear or pay a solemn sigh.

39
40 **8 - M Jr. Warden:** It is a great act of piety, and
41 honorable, to inter our Brethren according to the
42 proportions of their condition, and so to give
43 evidence that we appreciate the desire to imitate
44 their virtues. Solemn and appointed mourning are

1 good expressions of our affection for the departed
2 soul and of his worth and our value of him; and,
3 they have their praise in nature and in manners
4 and in public customs. Something is to be given
5 to custom, something to fame, to nature and to
6 civilities.

7

8 **9 - M Orator:** My Brethren, it is an act of grace
9 and wondrous mercy that we are admitted to speak
10 to the Eternal God, to make plaint to Him as to a
11 Father, to beg of Him remedy and ease, support and
12 counsel, health and safety, deliverance and
13 salvation. Wherefore, since this sorrow has
14 fallen upon us and the Lord hath commanded us, in
15 such cases, to pray unto him, let us ask of Him
16 power and assistance to do our duty and His favor
17 for those; who are afflicted in even greater
18 measure than ourselves. **LET US PRAY:**

19

20 Our Heavenly Father, as it hath pleased Thee
21 to take from our ranks one dear to our hearts, we
22 beseech Thee to bless and sanctify unto us this
23 dispensation of Thy providence. Look upon us, and
24 upon those whom this Death has more sadly bereaved
25 and distressed, in mercy and pity! Support us,
26 and them, by the strength of Faith in all
27 afflictions, and refresh us, and them, with the
28 comforts of a holy hope in all sorrows! All help
29 cometh from Thee; from Thee flows all comfort and
30 consolation. Be Thou our strength and our guide,
31 preserve us from sin, keep us in peace and
32 holiness and help us to serve Thee in thankfulness
33 and obedience, granting to us, in this world,
34 knowledge of Thy Truth and, in the world to come,
35 life everlasting. Amen.

36

37 **All:** So Mote it be!

38

39 **6 - M Wise Master:** Brother Sr. Warden, what is our
40 first duty in this sorrow that has fallen upon us?

41

42 **7 - M Sr. Warden:** Wise Master, to submit without
43 murmuring to the dispensations of our Father who
44 is in Heaven, to pay Him the profoundest homage,

1 knowing that all He wills is infinitely wise and
2 just, and to trust implicitly in His inexhaustible
3 mercy; for we are assured that the dead shall live
4 again. Our Brother is not here. This body over
5 which we mourn is not he, but only that which was
6 his human and material part, until God laid His
7 finger on him and he slept. He was mortal; but he
8 has now put on immortality. In what state and
9 where he is, we do not know; but only that he has
10 not ceased to be and that he is in the hands of
11 his Father, Who loves and pities him, as He doth
12 all the children He hath made.

13

14 **6 - M Wise Master:** Brother Jr. Warden, what is the
15 second duty this misfortune imposes upon us?

16

17 **8 - M Jr. Warden:** Wise Master, to inter the body
18 of our Brother after the manner of Masonry,
19 knowing that when we do this for our dear friend,
20 it is not done to a person undiscerning, as a
21 fallen tree, but to one whose soul yet lives and
22 peradventure would perceive our neglect and be
23 witness of our transient affections and
24 forgetfulness; and, if that not be so, yet God
25 sees us, and solemn reverence is due the dead, who
26 are now nearer God, than we, that are yet for a
27 little while imprisoned in the body. Death is
28 that harbor whither God hath designed everyone,
29 that there he may find eternal rest.

30

31 **9 - M Orator:** Very eloquent are the still lips of
32 the dead! With a pathos and impressiveness that,
33 no living lips can equal, or even approach, though
34 they may have been sanctified and made prophetic
35 by coals from the Holy Altar, laid upon them by
36 Angels, these lips preach to us a sermon that
37 cannot be translated into words. Most eloquently
38 they tell us how vain and empty are all the
39 ambitions, hatreds, jealousies, the disputes and
40 rivalries, the struggle for wealth and place and
41 power, for rank and reputation of human life. How
42 indifferent now to praise or censure, to
43 undeserved eulogy or equally undeserved blame, to
44 all the prizes of human ambition, to all the

1 glories of human greatness, to all the beatitudes
2 of human love.

3

4 **6 - M Wise Master:** It is a common thought that in
5 the grave all men are equal; the fortunate and the
6 unfortunate, the humble and the great, for there
7 they mingle their dust, while God and the Angels
8 only can distinguish their souls.

9

10 **8 - M Jr. Warden:** Our mortal life is but a span
11 long. The days of our pilgrimage are few.
12 Everywhere around us, as we look out into the
13 night, we can see the faces of those we have loved
14 and who have fallen asleep before us, shining upon
15 us like stars.

16

17 **7 - M Sr. Warden:** While we think a thought we die
18 and the clock strikes and reckons on our portion
19 of Eternity. We form our words with the breath of
20 our nostrils and have the less to live upon, for
21 every word we speak; and those things that can
22 survive us, our works, our words, our immortal
23 thoughts, our influences, and the effects of our
24 good deeds, are more to the world that survives,
25 than we ourselves are. We pass away and are
26 forgotten but these continue to live. Let
27 selfishness and especially the selfishness of
28 vice, learn this lesson and changing, endeavor to
29 leave something to live beyond their passing.

30

31 **9 - M Orator:** Once our Brother lived and labored:
32 but now his star is set on this world and he has
33 passed into the Light that lies beyond the
34 darkness. We shall no more hear his voice, until
35 we also have awakened in another world. Let us,
36 then, not mourning like those that have no hope,
37 pay the last offices of pious duty to the dead;
38 since he, like one who sails slowly away from the
39 shore of a dear land, a little while ago familiar
40 to him, and hears in the stillness of the night
41 the murmur of our voices and sees, as the Angels
42 do, these obsequies and the evidences of our
43 affection.

44

Next Music
(2)
CD - 1
Track-5

1 **6 - M Wise Master:** I adjure you, my brethren, by
2 this Holy Symbol of the Rosy Cross, the emblem of
3 Faith, Hope and Immortality, not to permit your
4 duties to the dead to cease with these sad
5 ceremonies. Right his cause; do justice to his
6 memory; defend his reputation. Thus, let us all
7 prove ourselves true Knight Rose Croix and good
8 Masons.

9
10 It Remains that we who are alive should so
11 live, and by our actions attend the coming of the
12 day of fate, that we neither be surprised nor
13 leave our duties imperfect, our sins uncanceled
14 and our persons unreconciled; but that when our
15 bodies return to the elements, our souls may
16 ascend to the regions of eternal Light, wherein is
17 the Hold House of the Heavenly Temple of the Lord.

18
19 God has written manifold and wondrous truths
20 in the stars; but the revelations of His love is
21 no less plain in the flowers that are the stars of
22 the earth. "Emblems of our great resurrection,
23 emblems of the brighter better land". We strew
24 them on the body (casket) of our Brother as an apt
25 expression of our affection and equally, of hope
26 and of reliance on that beneficence of which they
27 are the unmistakable of eloquent expression.

28
29 Be not sad, my Brethren, but let us rejoice
30 that these men lived, that we knew them, and that
31 they were one with us in the Mystic Bond of
32 Freemasonry. Let us celebrate their lives by
33 making the best of their examples. Amen.

Stop Music

34
35 **All -** So mote it be!

36
37
38
39
40
41
42
43
44

Raise Lights to 100% for Guest Speaker and Lower back to dark afterwards	1 [Optional Ten-minute address: Some Valleys may 2 desire to include a brief address at this point in 3 the ceremony. The Wise Master selects and 4 introduces both the speaker and the topic, but he 5 should ensure that the subject of the address is 6 in keeping with the spirit of the ceremony. In 7 any case, it is important to keep the audience in 8 mind and to limit the presentation to no more than 9 ten minutes. At the conclusion of the address, 10 the Wise Master thanks the speaker. Before 11 continuing with the ceremony, he waits until any 12 applause is over.] 13 14 GUEST SPEAKER: 15 16 Part Four: 17 18 Fiat Lux, Relighting of the Lights 19 20 Wise Master: *** (Three Raps) 21 22 S - ORATOR: Let us Pray! Let us, henceforth, 23 celebrate the lives of our Brethren who have 24 passed on, keeping them ever with us while we 25 live. Remember, no man is ever truly dead as long 26 as he lives in the hearts and memories of his 27 friends and loved ones, and if his influences 28 continue to act for good. So may it be with each 29 of you. So mote it be. 30 31 ALL: So mote it be. 32 33 Wise Master: * (One Rap) 34 35 36 37 38 39 40 41 42 43 44
--	--

Spotlight
on Orator

Spotlight
Out

Music (2)
CD-1
Track-5

Light
Tapers

1 **9 - Voice 1:** Brethren and Knights, at the
2 commencement of our Masonic careers, each of us
3 knelt before an altar and asked for Light. This
4 request granted, we came to understand that Light
5 is the primary Masonic symbol because it reveals
6 the world to us as it is. But Light is more than a
7 mere symbol, for life could not exist without it.
8 We are taught that every man is a ray of the
9 Divine Light and that we are to be Soldiers of the
10 Light, ever vigilant. And, although the lights of
11 Liberty, Equality, and Fraternity have been
12 extinguished from time to time upon the earth, yet
13 man bears within his breast the spark, which can
14 ignite these anew. "Let there be light" is both a
15 Divine command and a moral obligation. In humble
16 commemoration of that august event, I now say,
17 "Let there be light;" even the Light of Truth.

Raise
Lights as
lights are
switched
on

18
19 **[Voice 1 lights the first light, following the**
20 **same sequence used in extinguishing the lights.]**
21
22 **5 - Voice 1:** So may the light of Truth illuminate
23 the world.
24
25 **5 - Voice 2:** Equality and freedom are in the
26 hearts of all who consider the just welfare of
27 their neighbors. To deny a man these rights is to
28 deny an instinct given by the Great Architect of
29 the Universe.
30
31 **[Voice 2 lights the second light.]**
32
33 **5 - Voice 2:** So may the light of equality and
34 freedom illuminate the world.
35
36 **5 - Voice 3:** To walk uprightly in our several
37 stations before God and man is to make us as one
38 family of Brethren. Every true man concerns
39 himself with the welfare of both his family and of
40 humanity.
41
42 **[Voice 3 lights the third light.]**
43
44

1 **5 - Voice 3:** So may the light of true fraternity
2 illuminate the world.

3

4 **5 - Voice 4:** Man's unending quest is to
5 understand the nature of reality. To aid him in
6 this search, he developed science and philosophy,
7 which combat superstition and ignorance.

8

9 **[Voice 4 lights the fourth light.]**

10

11 **5 - Voice 4:** So may the light of knowledge and
12 wisdom illuminate the world.

13

14 **5 - Voice 5:** At some time in life, all men find
15 themselves in need. To give to the less fortunate
16 without the hope or expectation of recompense is
17 the practice of Charity. We are taught to have
18 fervent Charity, for Charity shall cover the
19 multitude of sins.

20

21 **[Voice 5 lights the fifth light.]**

22

23 **5 - Voice 5:** So may the light of Charity
24 illuminate the world.

25

26 **5 - Voice 6:** The purpose of true initiation is
27 self-realization. "Know thyself" is at once the
28 dictum of sages and the greeting placed above the
29 doorways of ancient temples. When we realize who
30 and what we are, we not only seek to improve our
31 own lives but also the lives of others. The great
32 teachers of every age have proclaimed that the
33 immortal part of man is a ray of the Divine Light
34 and that we are all children of the Most High.

35

36 **[Voice 6 lights the sixth light.]**

37

38 **5 - Voice 6:** So may the light of self-realization
39 illuminate the world.

40

41

42

43

44

1 **5 - Voice 7:** Protection from brutality and the
2 exercise of individual liberty afford all other
3 freedoms. To deny any man his individual rights,
4 merely because his practices differ from our own,
5 is to deny him the measure of his creation. Man
6 has the right to live as he will, as long as he
7 does not hinder the rights of others.

8

9 **[Voice 7 lights the seventh light.]**

10

11 **5 - Voice 7:** So may the light of individual
12 liberty illuminate the world.

13

Lights up
100
Percent

14 **[The lights in the room are dramatically raised to**
15 **full intensity.]**

16

17 **1 - Wise Master:** Brothers Guardian of the Temple,
18 Expert, and Master of Ceremony attend the altar.

19

20 **The Guardian of the Temple and Expert go the north**
21 **and south of the altar. The Master of Ceremony**
22 **goes to the west of the altar and picks up the**
23 **Bible and holds it while the expert and Assistant**
24 **Expert turns the altar cloth. The Master of**
25 **Ceremony returns the Bible.**

26

27 **1 - WISE MASTER:** Brethren and Knights, the Word
28 of Life and Regeneration is recovered, and the Law
29 of Love lives! We are to proclaim it and to live
30 it so that we may be worthy of the titles and
31 honors we bear. Let us forever unite to protect
32 the rights of others and, thus, of ourselves.
33 When labors are to be placed upon our shoulders,
34 let us remember those who sacrificed for us and
35 did not shirk the call to duty. May Liberty,
36 Equality, and Fraternity reign supreme, and may
37 the Great Architect grant that we meet again in
38 this group next year, in the bonds of unity and
39 peace.

40

41

42

43

44

Three Raps	1 [Wise Master raises both hands, palms open, above 2 head.] *** (Three Raps) 3 4
Raises both hands	5 Wise Master: Brethren, Knights and guests, I give 6 to you all the hope of spring renewed with its 7 attendant bounty. May Brotherly Love prevail, and 8 may we ever be united in every social and moral 9 virtue, cemented in the mystic and universal bond 10 of Masonic Brotherhood. Amen. 11 12 ALL: So mote it be. 13
1 Rap	14 1 - Wise Master: Brethren and guest. This 15 concludes our program for the night. Thank you 16 for coming may health and happiness go with you 17 for the next year. Please go in peace. 18 19 * (One Rap)